

## INTRODUCTION

Thank you for your purchase of the HA43Pro Reference Headphone Amplifier. The HA43Pro drives up to four pairs of stereo headphones for high quality audio monitoring. The unit is intended for sound reinforcement, studio, choir, install, and other applications where a smaller size is desired without sacrificing audio quality.

## SPECIFICATIONS

Input Impedance: 100k Ohms unbalanced  
Max Input Level: +14 dBV  
Input Connectors: TRS Stereo 1/4" phone, Dual RCA  
Outputs: 4 TRS Stereo 1/4", 4 TRS Stereo 1/8" (3.5mm)  
Output Impedance: 51 Ohms each output  
Max Gain: 20 dB/Channel  
S/N Ratio: >90 dB  
THD: < .008%  
IMD (SMPTE): <.008%  
Power: 12 VDC (Rolls Model PS27)  
Weight: 1 lb (.45 kg)  
Size: 4.15 x 3.45 x 1.16 (W x H x D)

## DESCRIPTION

INPUTS: 1/4" Stereo TRS jack, and Dual RCA jacks for connection to the stereo line-level signals to be monitored.  
12 VDC PWR: Connects to the Rolls PS27 12 VDC (outside of the barrel positive) adapter.  
CHANNEL LEVELS: Sliders 1 - 4 adjusts the level of the indicated channel.  
OUTPUTS 1 - 4: 1/4" and 1/8" (3.5mm) TRS stereo jacks for connection to headphones or earphones.

## WARRANTY INFO

Please visit our website, [www.rolls.com](http://www.rolls.com), for the Rolls 1 Year Warranty information and registration.

## SCHEMATIC

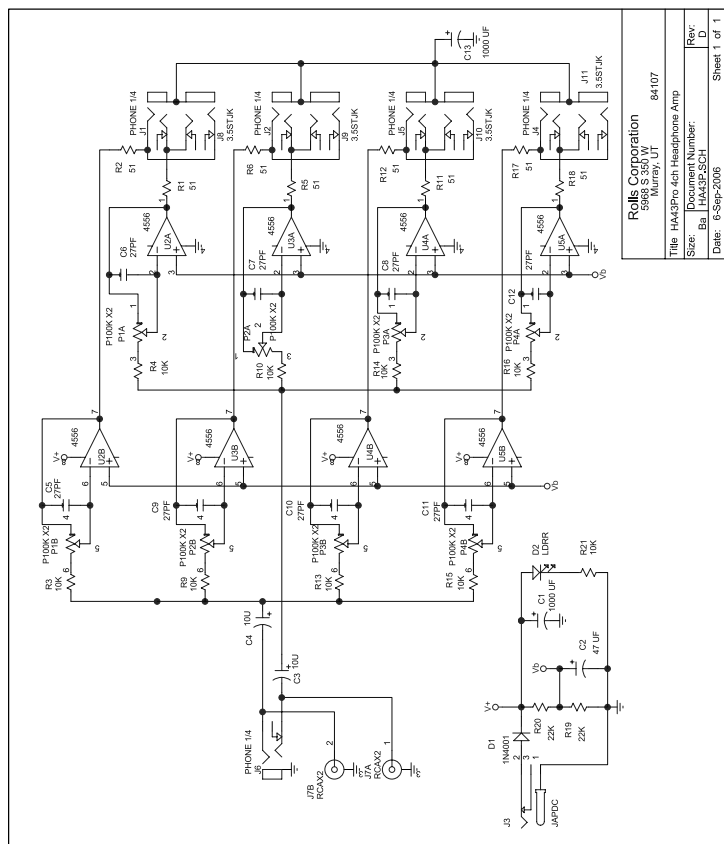

... anywhere you need four channels of clean, loud headphone amplification.

# ROLLS

- Broadcast  
- School  
- Studio

## HA43 Pro 4 Channel Headphone Amp

## 4-Ch. Studio Headphone Amp

## HA43 Pro

# ROLLS

## HA43 Pro 4-Channel Studio Reference Headphone Amplifier

The HA43 Pro is a full frequency response four channel headphone monitoring device designed for the recording studio, or other professional applications like listening rooms and monitoring stations. Each output boasts a whopping 20 dB of clean channel gain.

- Stereo 1/4" and Dual RCA Inputs
- Slider Volume controls
- AC adapter included
- Full frequency response
- Lots of output level.... it's loud!

HA43p Headphone Amp



Rolls Corporation  
Salt Lake City, UT  
9/06

